



The history of Elephant is rooted in tradition, though it was officially established in 1979, when it started its own activity to resolve the problems linked to the handling of materials in the industrial and craft fields.

Today, thanks to the owners' passion and entrepreneurial spirit as well as the technical staff's skills, Elephant has reached key milestones in the production process, aimed at product innovation and improved customer service, thus achieving a considerable increase in production, also thanks to the acquisition of technologically advanced machinery and the growth of the company.

This experience gained over the years, together with the company's progressive development in the lifting and handling sector, has allowed Elephant to manufacture more than 70000 plants distributed throughout the world.

As far as the production of cranes and vacuum lifters is concerned, Elephant can offer its customers an appropriate response to specific handling demands for any type of load.

Its technical, specialised and qualified personnel manufactures customised prototypes based on specific customer requirements, thus providing concrete answers to the multiple and diverse automation and production needs in the fields of manufacturing, engineering, marble, wood, glass, to name but a few.



PRODUCTION

Column-mounted and bracket-mounted jib cranes with: profiled channel arm, cantilever arm, tie-rod girder arm, articulated arm, sliding arm, with palletised base, **channel-type overhead systems, electrical overhead bridge cranes, cranes with 360° electrical rotation, cranes with 360° manual rotation, tongs, clamps and rocker arms.**

Vacuum lifters: models with one, two, three, four or more suction plates, working with compressed air or an electric pump unit for vacuum, fixed structure or with manual, pneumatic or electric tilting, suitable for self-propelled machines. Special vacuum lifters are available upon request.



L'histoire de Elephant est ancrée dans la tradition, même si sa naissance officielle remonte à 1979, lorsqu'elle a démarré son activité pour résoudre les problèmes liés à la manutention des matériaux

dans les domaines industriel et artisanal. Aujourd'hui, grâce à la passion et au dynamisme des propriétaires ainsi qu'au professionnalisme de son équipe technique, Elephant a franchi des étapes incontournables dans le processus de production, visant à l'innovation du produit et à l'amélioration des services pour sa clientèle, ce qui a permis une montée en flèche de la production, grâce également à l'acquisition d'équipements technologiquement avancés et à l'élargissement de l'entreprise. Cette expérience acquise au fil des années, qui est allée de pair avec le développement progressif de l'entreprise dans le secteur du levage et de la manutention, a permis à Elephant de réaliser plus de 70000 installations distribuées dans le monde entier. Pour ce qui est de la production de grues et de palonniers à ventouses, Elephant est à même d'offrir à ses clients une réponse appropriée à toutes les demandes spécifiques de manutention de n'importe quel type de chargement. En effet, son personnel technique, spécialisé et qualifié, réalise des prototypes personnalisés suivant les demandes spécifiques du client, tout en fournissant des réponses concrètes aux besoins multiples et différenciés en termes d'automatisation et de production dans les secteurs manufacturier, métallurgique et mécanique, du marbre, du bois, du verre, pour n'en citer que quelques-uns.



LA PRODUCTION

Potences sur fût et murales avec: flèche en profil creux, flèche inversée, flèche triangulée, flèche articulée, flèche coulissante, avec embasement palettisé, **installations suspendues en profil creux, ponts roulants électriques suspendus, grues à rotation électrique 360°, grues à rotation manuelle 360°, pinces, bornes et palonniers.**
Palonniers à ventouses: modèles à une, deux, trois, quatre plaques d'aspiration ou plus, fonctionnant à l'air comprimé ou avec groupe pour vide électrique, structure fixe ou avec basculement manuel, pneumatique ou électrique, adaptés pour machines automotrices. Il est également possible de réaliser des palonniers à ventouses spéciaux sur demande.



FACASAP TECHNOLOGY SOLUTION COMPANY LIMITED
TIN: 0317505426
Floor 5, 15 Tran Khac Chan, Tan Dinh Ward, District 1, HCMC.



it



Vacuum lifters for wood



La storia della Elephant ha origini ricche di tradizioni, anche se la sua nascita ufficiale risale al 1979, quando ha iniziato la propria attività per risolvere le problematiche connesse alla movimentazione dei materiali in campo industriale ed artigianale. Oggi, grazie alla passione e al dinamismo dei titolari ed alla professionalità del proprio staff tecnico, la Elephant ha compiuto un cammino progressivo nel processo produttivo, finalizzato all'innovazione del prodotto e al miglioramento dei servizi alla clientela conseguendo in tal modo un notevole incremento della produzione, grazie anche all'acquisizione di macchinari tecnologicamente avanzati ed all'ampliamento dell'azienda. Tale esperienza maturata negli anni, insieme al progressivo sviluppo aziendale nel settore del sollevamento e della movimentazione, ha permesso alla Elephant la realizzazione di oltre 70.000 impianti distribuiti in tutto il mondo.

Nella produzione di gru e ventose la Elephant è in grado di offrire ai propri clienti una adeguata risposta alle specifiche richieste di movimentazione di qualsiasi tipologia di carico. Infatti, il suo personale tecnico, specializzato e qualificato, realizza prototipi personalizzati su specifiche richieste del cliente, fornendo risposte alle molteplici e diverse esigenze di automazione e produzione nei settori manifatturiero, metalmeccanico, del marmo, del legno, del vetro, per citarne solo alcuni.



LA PRODUZIONE

Gru a bandiera a colonna e a mensola con: braccio profilato in canalina, braccio in trave a sbalzo, braccio in trave tirantata, braccio snodato, braccio scorrevole, con basamento palettizzato; **impianti sospesi in canalina, carriponte elettrici sospesi, gru con rotazione elettrica 360°, gru con rotazione manuale 360°, pinze, morsetti e bilancini.** Ventose a una, due, tre, quattro o più piastre aspiranti, funzionanti ad aria compressa o con gruppo pompante elettrico, struttura fissa o con basculamento manuale, pneumatico o elettrico, adatte per mezzi semoventi. Si realizzano modelli speciali su richiesta.



PANELS / PANNEAUX

Ventose pneumatiche con movimenti manuali o automatici per pannelli traspiranti e non traspiranti

*Pneumatic vacuum lifters with manual or pneumatic movements for breathable panels and not breathable panels
 Palonniers à ventouses pneumatiques avec mouvements manuels ou pneumatiques pour panneaux transpirants et panneaux non transpirants*

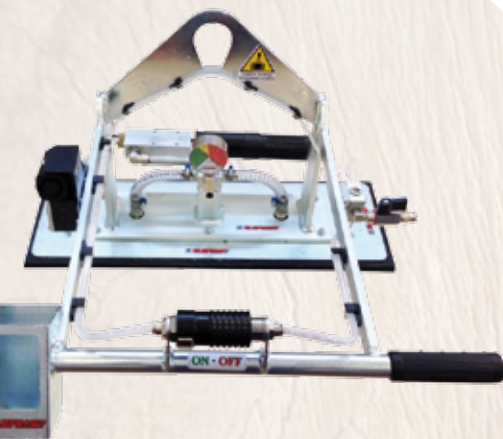

Modello Model Modèle	Portata (kg) Capacity Charge maximale
PNT1F-R	125
PNT2F-R-RP	125/150/200
PNT4F-R-RP	200/250/300
PNT6F-R-RP	200/250/300

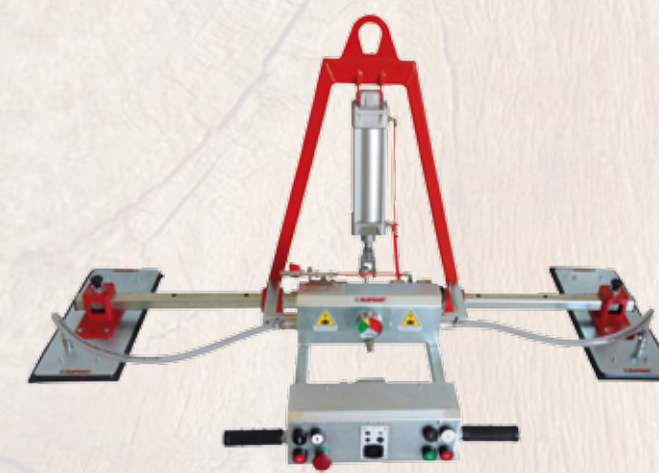
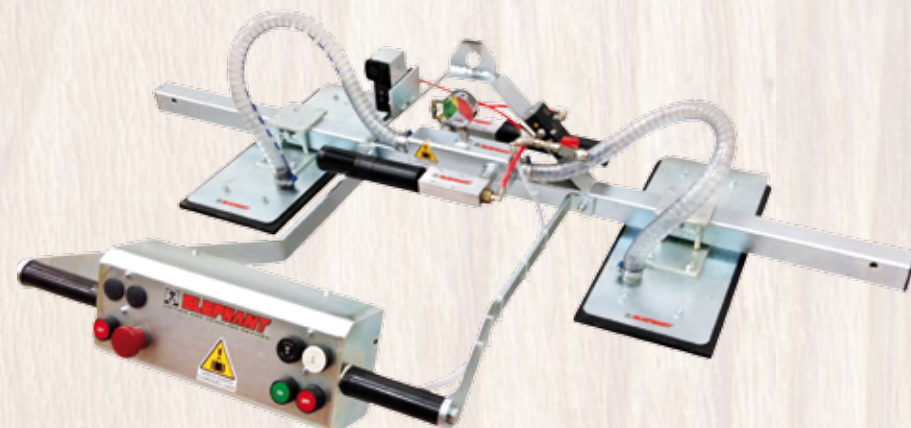

Modello Model Modèle	Portata (kg) Capacity Charge maximale
PN1F-R	125/250/500
PN2F-R-RP	125/250/500

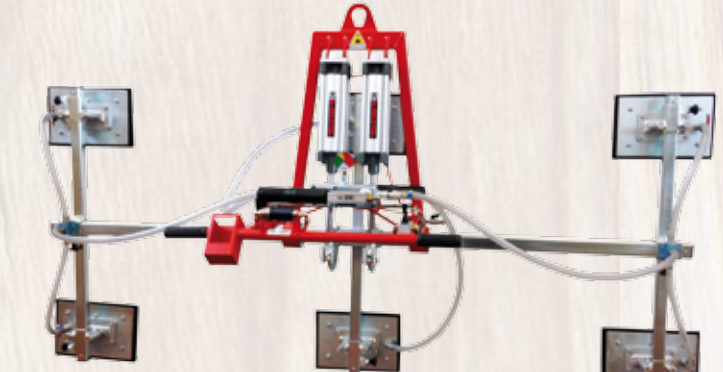
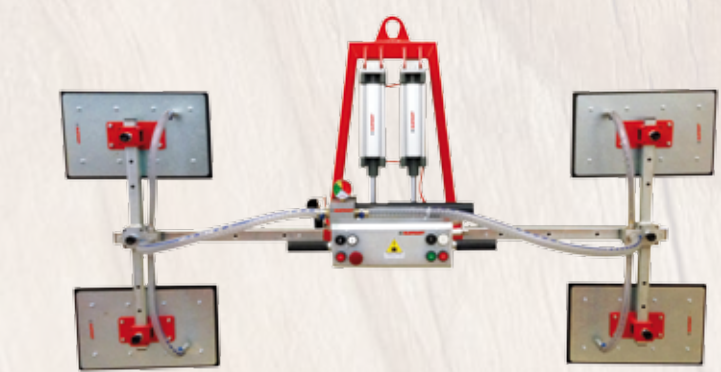
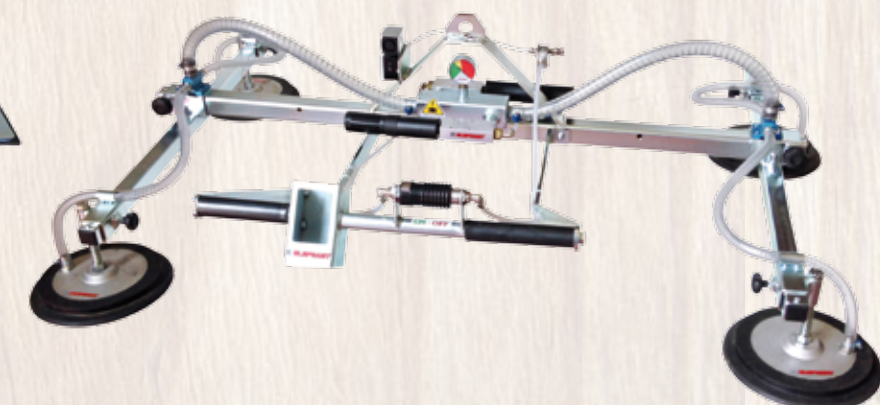

*F Fissa in orizzontale/Fixed in horizontal/Fixe à l'horizontale
 R Basculamento 0-90° manuale/0-90° manual tilting/Basculement 0-90° manuel
 RP Basculamento 0-90° pneumatico/0-90° pneumatic tilting/Basculement 0-90° pneumatique

DOORS / PORTES



Modello Model Modèle	Portata (kg) Capacity Charge maximale
PNT4F-R-RP	50/80/100/125/150
PN4F-R-RB	50/80/100/125/150

Ventose pneumatiche con movimenti manuali o automatici per porte

*Pneumatic vacuum lifters with manual or pneumatic movements for doors
 Palonniers à ventouses pneumatiques avec mouvements manuels ou pneumatiques pour portes*

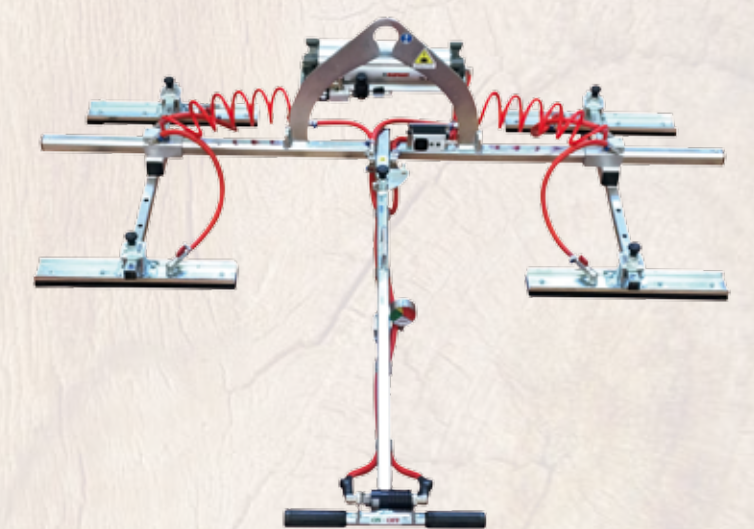

BASCULAMENTO PNEUMATICO 0-180°
 0-180° PNEUMATIC TILTING / BASCULEMENT 0-180° PNEUMATIQUE

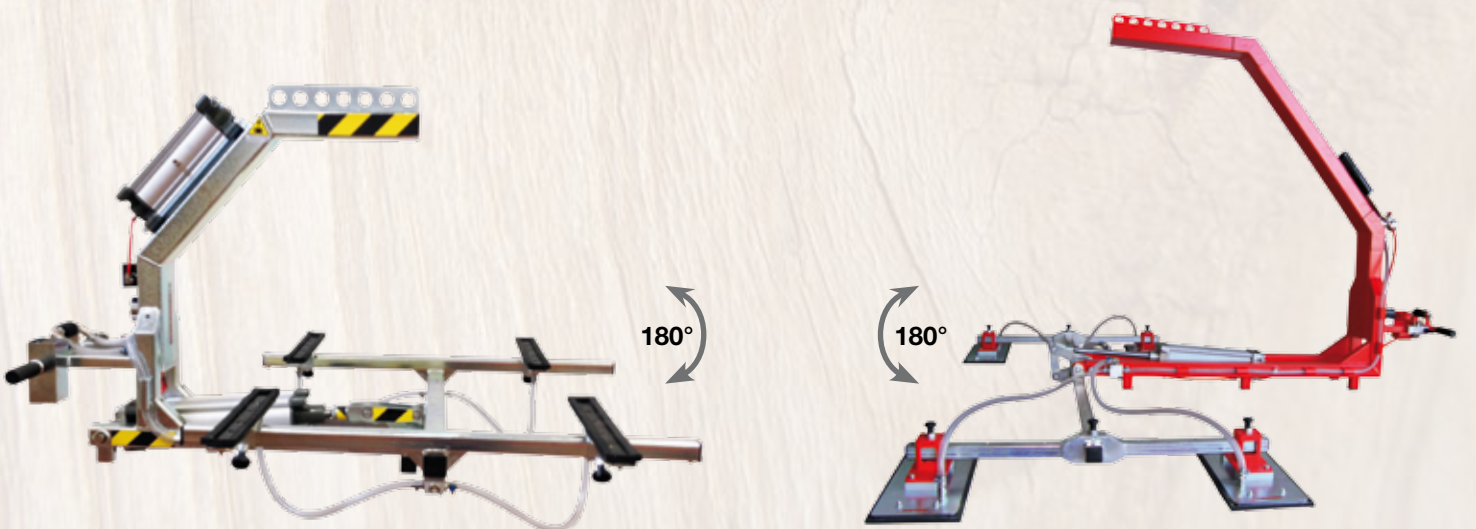

WOODEN BEAMS AND BOARDS / POUTRES ET TRANCHES

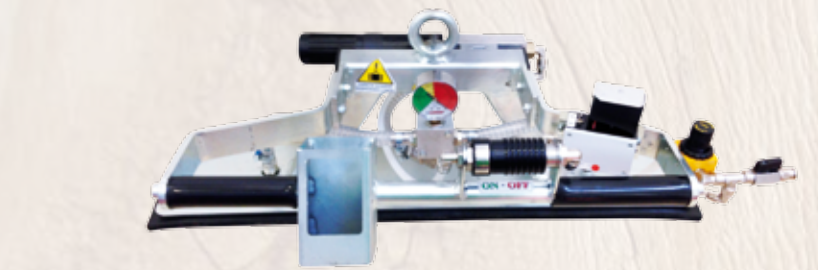

Modello Model Modèle	Portata (kg) Capacity Charge maximale
TV1	300
TV2	250/500/700
TV3	500
TV4	700
TV6	1000

Ventose pneumatiche per travi e tavolame

*Pneumatic vacuum lifters for wooden boards and beams
 Palonniers à ventouses pneumatiques pour poutres et tranches*

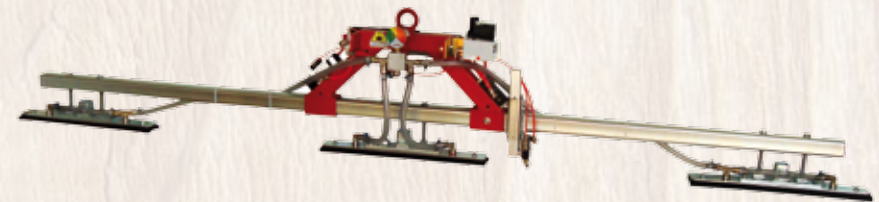

Manico con pulsanti per il comando del sollevatore a ventosa e del paranco
*Handle with buttons for both the control of the vacuum lifter and the hoist
 Poignée avec commandes pour le contrôle du palonnier et du palan*

Manico longitudinale telescopico fornito in alternativa al manico centrale standard

*Telescopic longitudinal handle in alternative to the central standard
 Poignée télescopique longitudinale en alternative à la centrale standard*

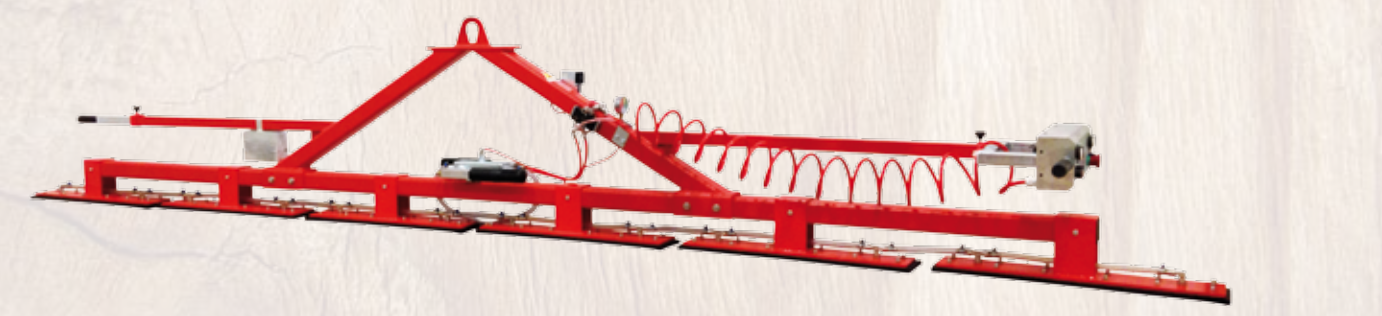

SOLUZIONI SPECIALI ELETTRICHE CON UPS PER PANNELLI TRASPIRANTI
 SPECIFIC ELECTRIC SOLUTION WITH UPS FOR BREATHABLE PANELS
 SOLUTIONS ELECTRIQUES SPECIFIQUES AVEC UPS POUR PANNEAUX TRANSPIRANTS

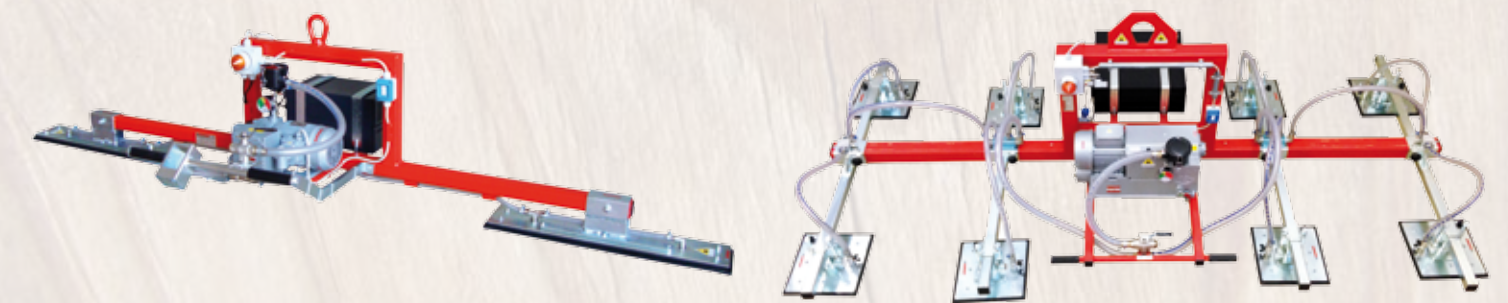

Soccorritore UPS a bordo che interviene in caso di emergenza evitando il distacco del materiale dal sollevatore a ventosa funzionante a 220V monofase 50 Hz
*Rescuer UPS on board that operates in case of emergency avoiding the detachment of the material from the vacuum lifter powered at 220V single phase 50Hz
 Groupe de secours UPS à bord qui intervient en cas d'urgence en évitant le détachement du matériel de la ventouse fonctionnant à 220V monophasé 50Hz*

OPTIONALS

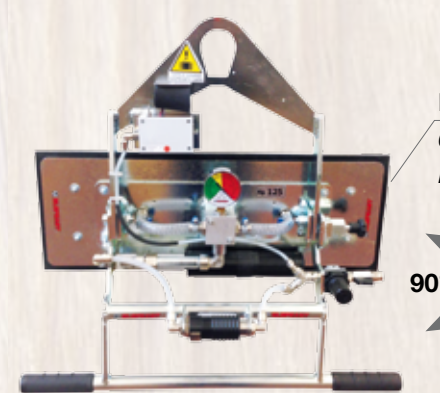

Basculamento 0-90° manuale
 0-90° manual tilting
 Basculement 0-90° manuel

Con carter e comandi integrati
*With carter and integrated controls
 Avec carter et commandes intégrées*

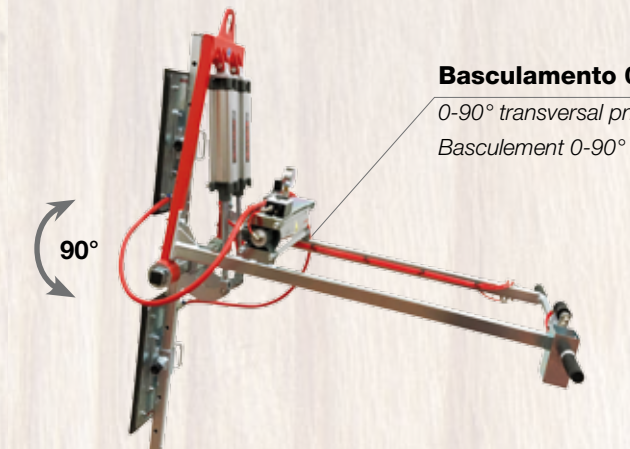
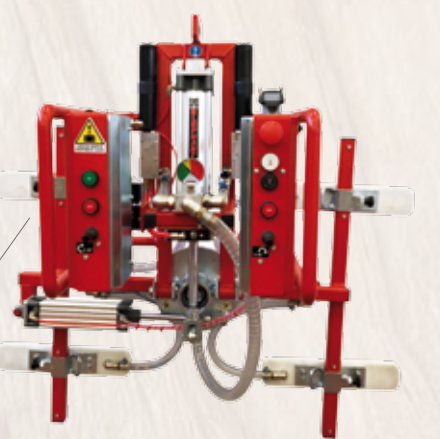

Basculamento 0-90° pneumatico trasversale
 0-90° transversal pneumatic tilting
 Basculement 0-90° pneumatique transversale

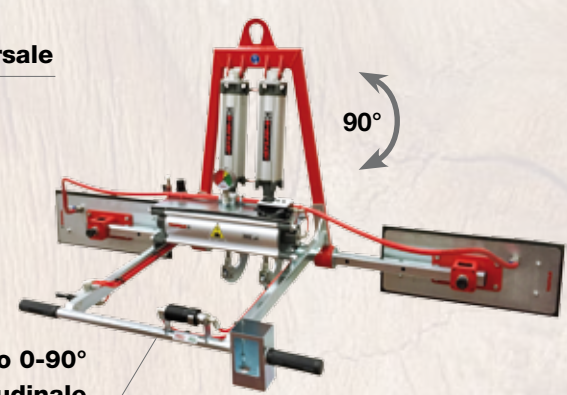

Basculamento 0-90° pneumatico longitudinale
 0-90° longitudinal pneumatic tilting
 Basculement 0-90° pneumatique longitudinale

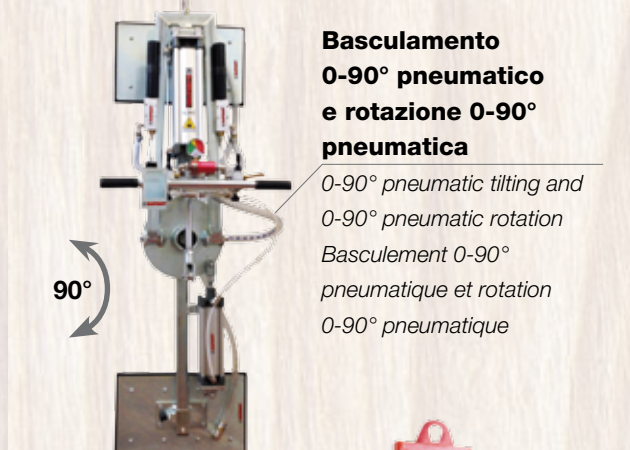

Basculamento 0-90° pneumatico e rotazione 0-90° pneumatica
 0-90° pneumatic tilting and 0-90° pneumatic rotation
 Basculement 0-90° pneumatique et rotation 0-90° pneumatique

Soluzione ribassata
*Lowered solution
 Solution hauteur réduite*

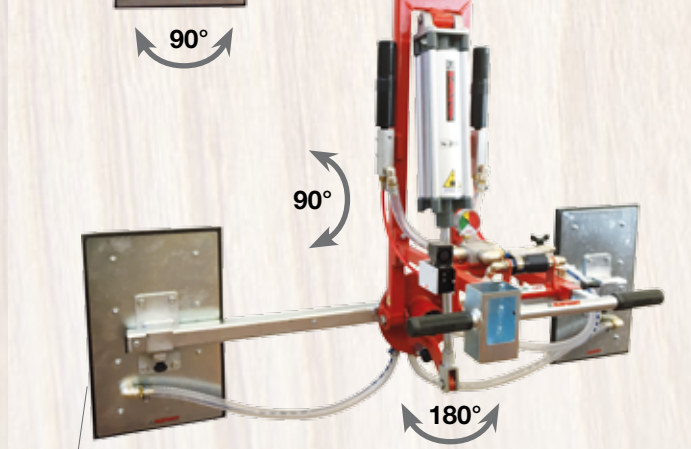
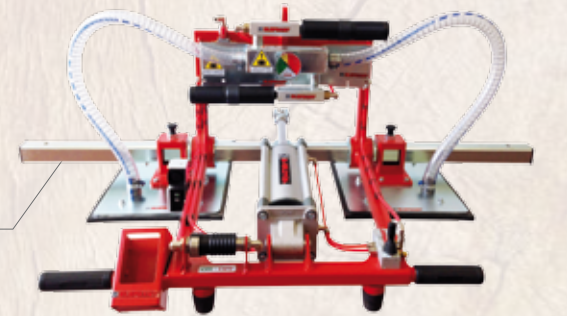

Basculamento 0-90° pneumatico e rotazione manuale
 0-90° pneumatic tilting and manual rotation
 Basculement 0-90° pneumatique et rotation manuelle

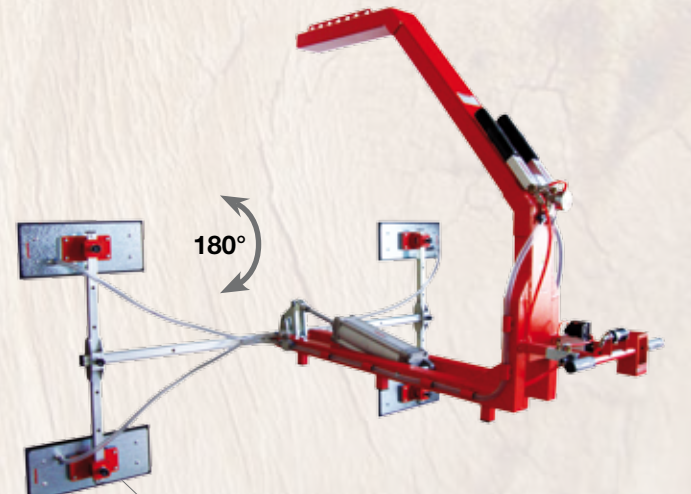

Basculamento 0-180° pneumatico
 0-180° pneumatic tilting
 Basculement 0-180° pneumatique